

CODE	L mm [ft]
9600-1/...-ST1	1000 [3.28']
9600-2/...-ST1	2000 [6.56']
9600-3/...-ST1	3000 [9.84']

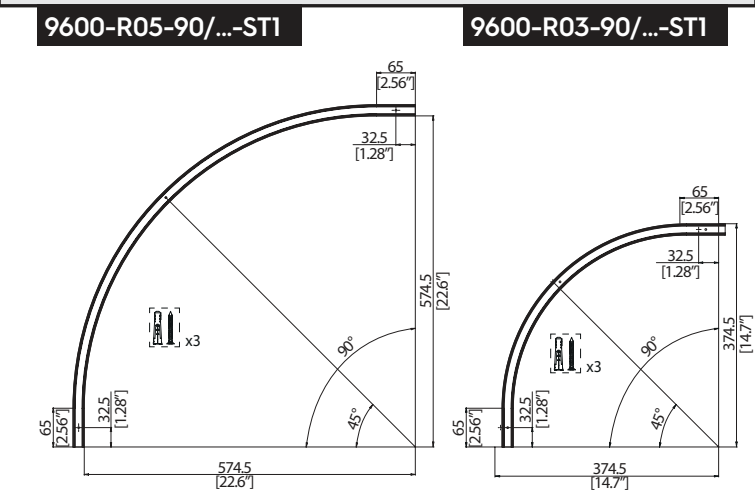

2 - USE

Ceiling

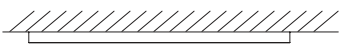

Wall



3 - CEILING FIXING

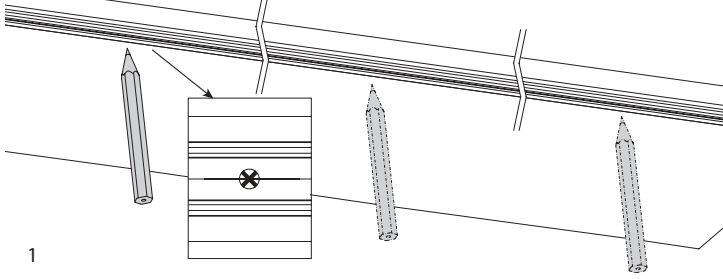

1

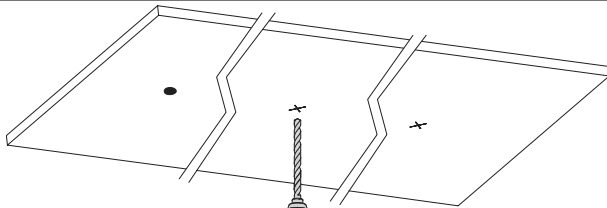

2

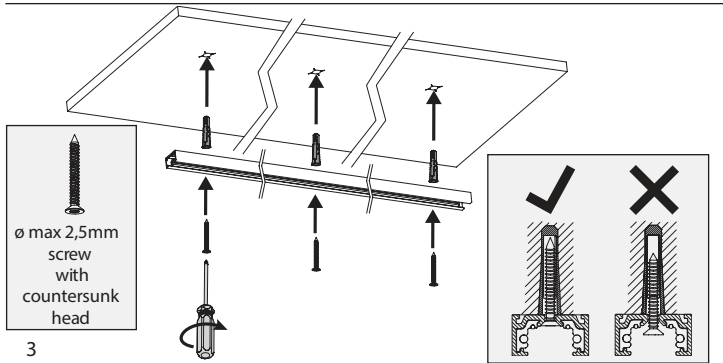

3

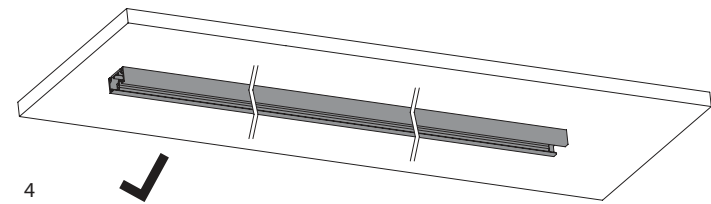

4

4 - 9601-E/B

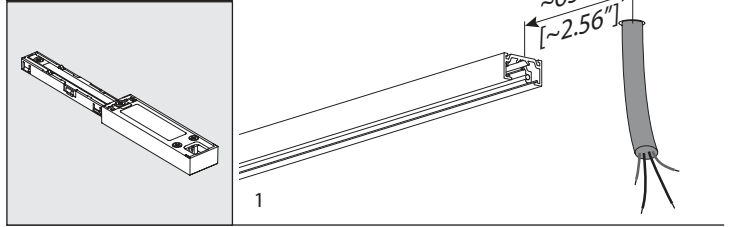

1

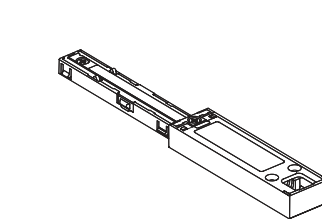

2

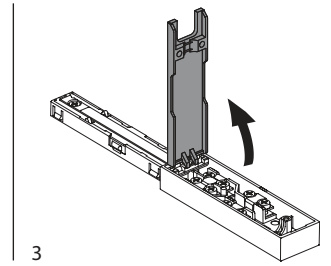

3

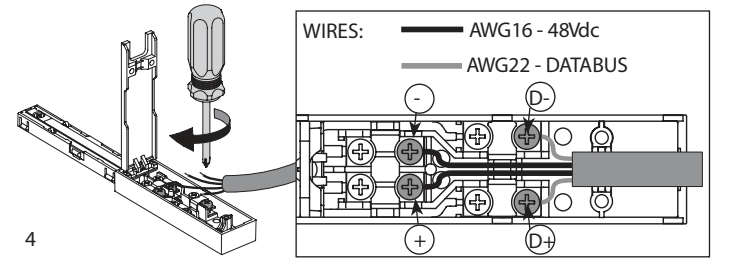

4

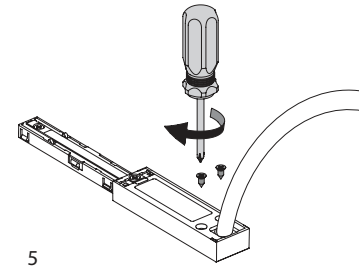

5

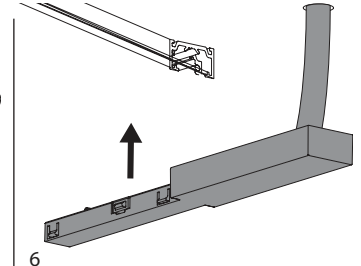

6

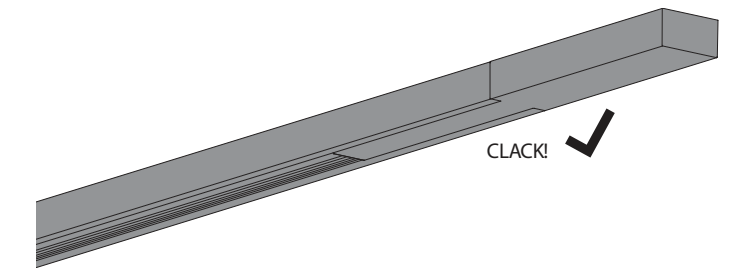

7

5 - 9601-S/B

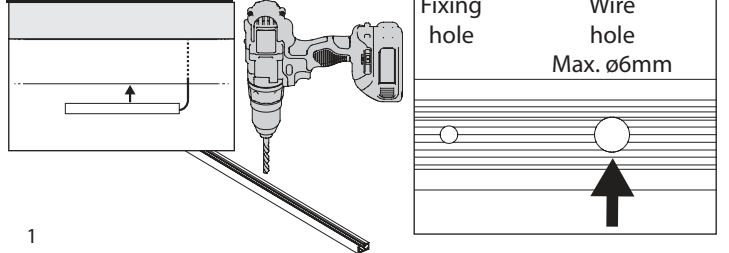

1

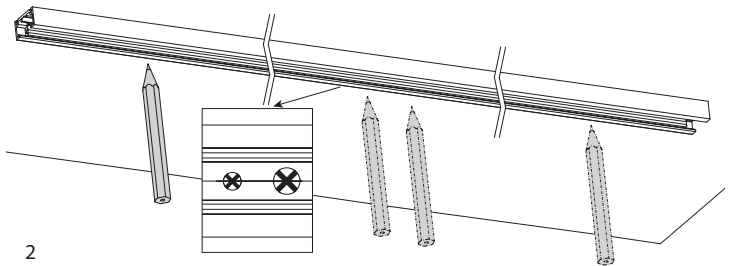

2

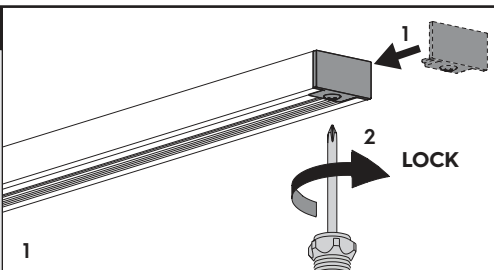
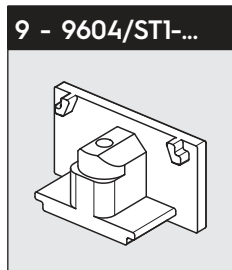
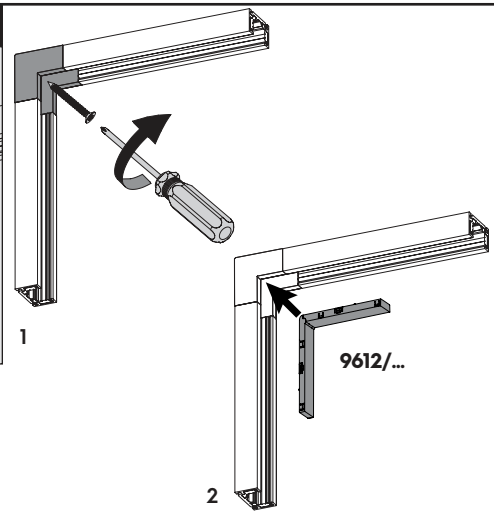
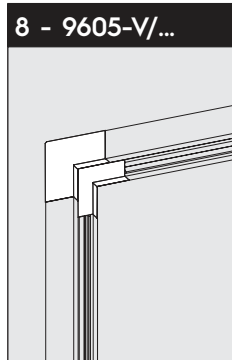
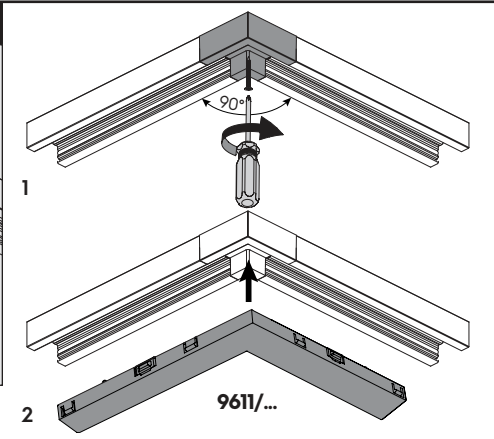
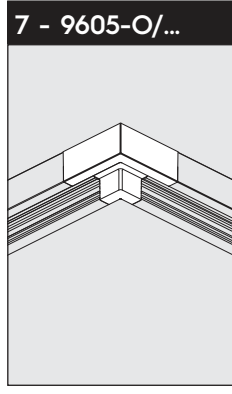
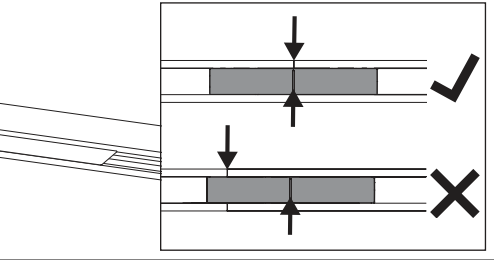
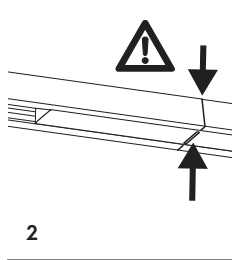
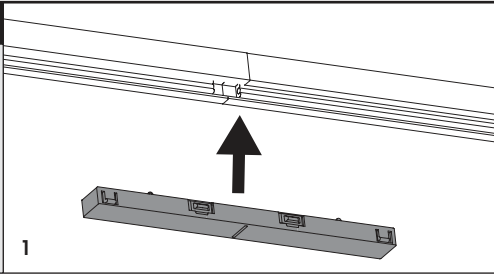
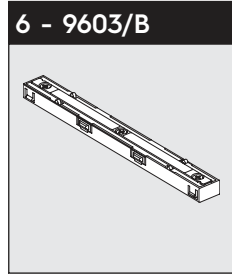
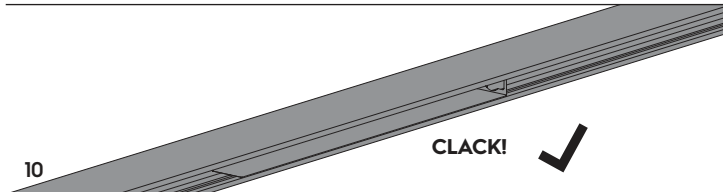
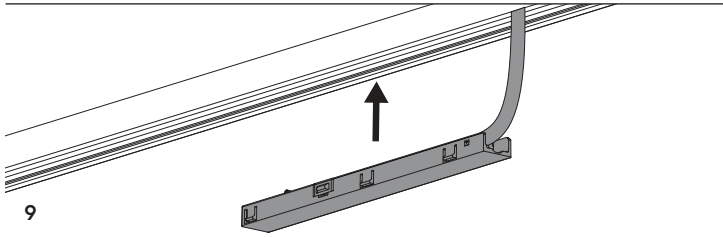
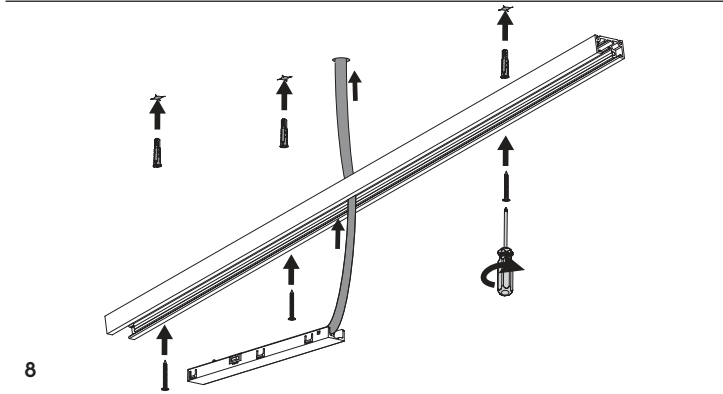
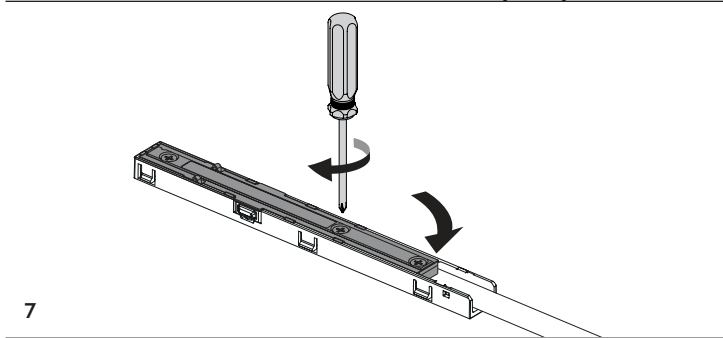
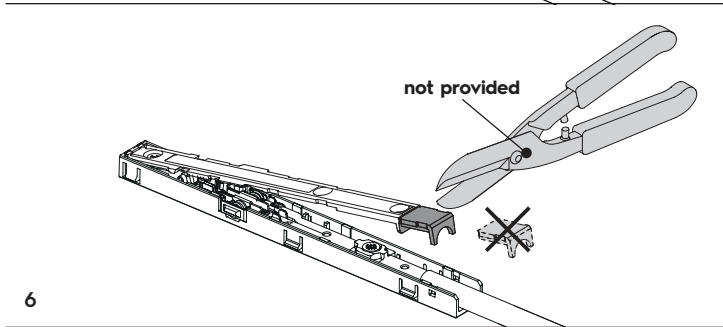
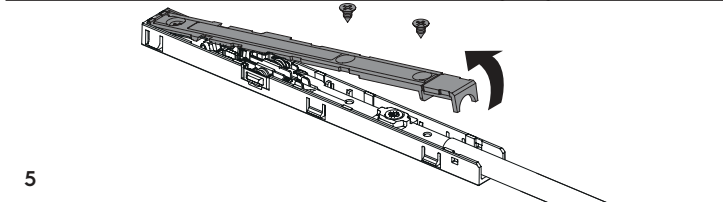
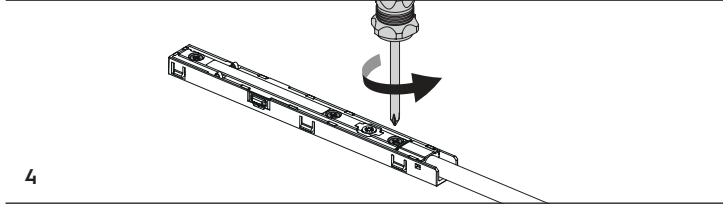
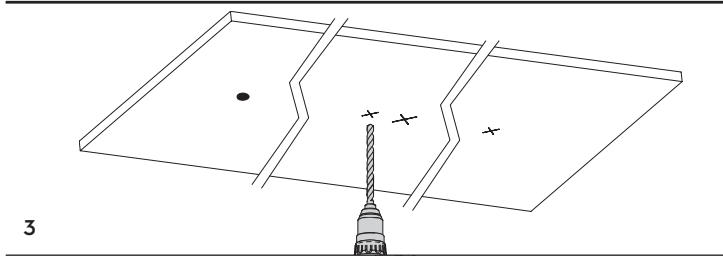

10 - WARNING

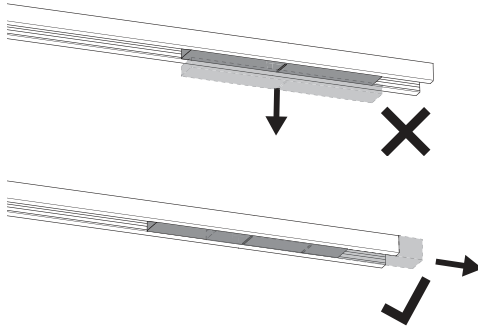

FOR ALL CONNECTIONS AND END-FEEDS

VALID FOR ALL MICRO TRACK SERIES

11 - CUTTING

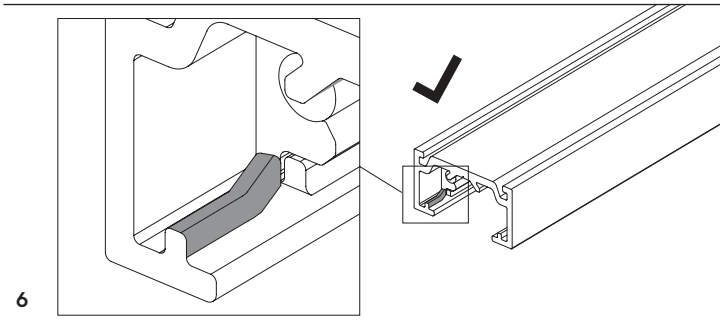
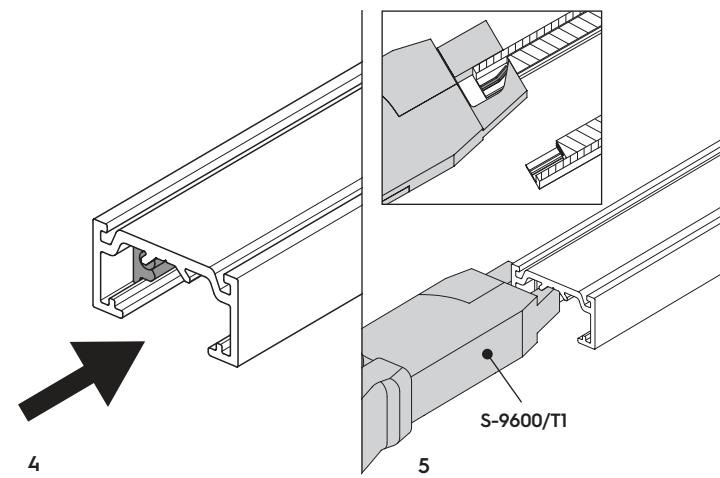
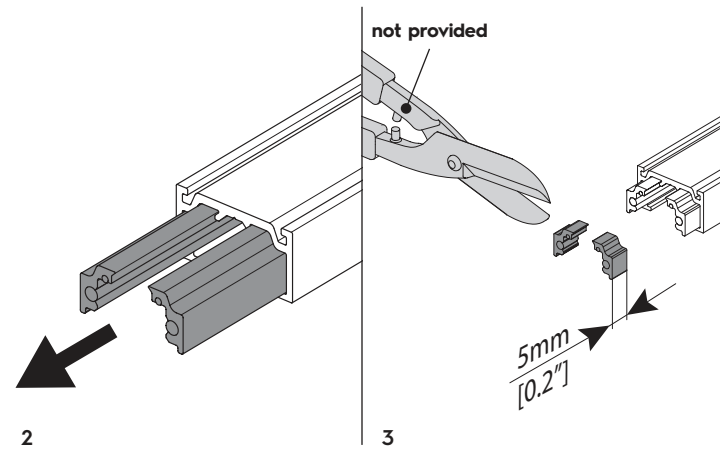
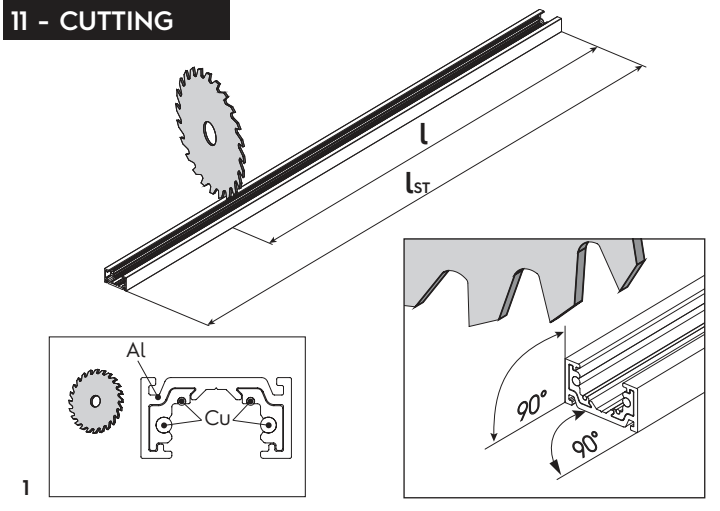

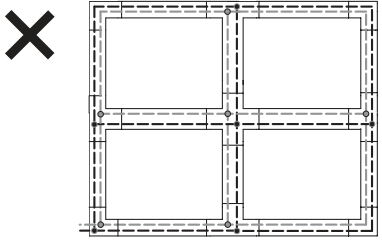
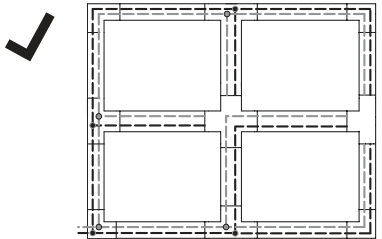
PLEASE ENSURE THAT THE DATA BUS WIRING DOES NOT CREATE A RING STRUCTURE. A FAILURE-FREE DATA BUS CANNOT BE ENSURED IF ONE IS PRESENT.

IF THE TRACK INSTALLATION REQUIRES THE USE OF "L", "T" OR "X" -SHAPED JOINT, IT IS POSSIBLE TO DISCONNECT THE DATA BUS IN THESE JOINTS TO AVOID CREATING A RING STRUCTURES.

--- Bus Data